

Structural Bearing Assemblies

Versiflex™ HLMR Pot Bearing Assemblies Uni-Directional PMG Series - 10%

Design Basis: AASHTO 17th Edition w/ Interims – Section 14

Rotation: 0.03 Radians

Horizontal Capacity: 10% of Vertical Capacity

Movement: X = ±0.063"

Y = As shown below

Steel Strength: Fy = 50 ksi

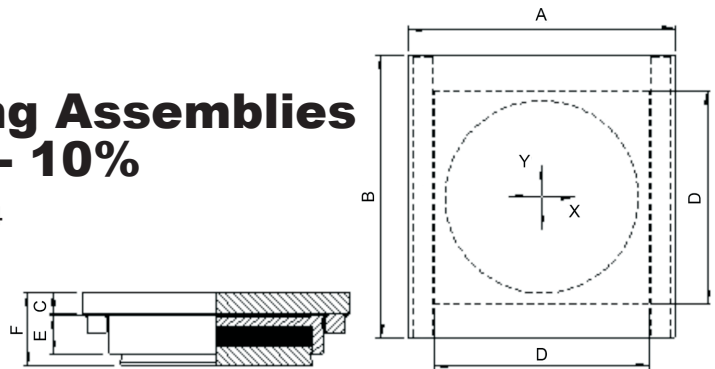

PMG SERIES - 10%

Model Number	Vertical Capacity (Klps)	Horizontal Capacity (Klps)	Y	Dimensions (in)					
				A	B	C	D	E	F
PMG100	100	10	3	12.00	12.75	1.00	7.750	1.750	3.875
PMG150	150	15	3	13.50	14.00	1.00	9.000	1.875	4.125
PMG200	200	20	3	14.75	15.25	1.00	10.250	2.125	4.250
PMG250	250	25	3	16.00	16.25	1.00	11.250	2.250	4.375
PMG300	300	30	3	16.75	17.00	1.00	12.000	2.500	4.750
PMG350	350	35	3	17.75	18.00	1.00	13.000	2.625	4.875
PMG400	400	40	3	18.75	18.75	1.00	13.750	2.750	5.000
PMG450	450	45	3	19.50	19.50	1.00	14.500	3.000	5.375
PMG500	500	50	3	20.25	20.25	1.00	15.125	3.000	5.375
PMG550	550	55	3	21.00	21.00	1.00	15.875	3.250	5.500
PMG600	600	60	3	21.75	21.75	1.00	16.625	3.250	5.625
PMG650	650	65	3	22.25	22.00	1.00	17.000	3.500	5.875
PMG700	700	70	3	23.00	22.50	1.00	17.500	3.625	6.000
PMG750	750	75	3	23.75	23.50	1.00	18.375	3.750	6.250
PMG800	800	80	3	24.25	23.75	1.00	18.750	3.875	6.375
PMG850	850	85	3	24.75	24.25	1.00	19.250	4.000	6.375
PMG900	900	90	3	25.50	24.75	1.00	19.750	4.000	6.375
PMG950	950	95	3	26.00	25.25	1.00	20.250	4.125	6.500
PMG1000	1000	100	3	26.50	25.75	1.00	20.750	4.250	6.750
PMG1100	1100	110	4	27.75	27.75	1.00	21.750	4.500	7.000
PMG1200	1200	120	4	28.50	28.50	1.00	22.500	4.625	7.125
PMG1300	1300	130	4	29.50	29.25	1.00	23.250	4.875	7.375
PMG1400	1400	140	4	30.50	30.25	1.00	24.250	5.000	7.500
PMG1500	1500	150	4	31.50	31.00	1.00	25.000	5.125	7.625
PMG1600	1600	160	4	32.25	32.00	1.00	25.875	5.375	8.000
PMG1700	1700	170	4	33.00	32.75	1.00	26.625	5.375	8.000
PMG1800	1800	180	4	34.00	33.50	1.00	27.375	5.625	8.375
PMG1900	1900	190	4	35.00	34.50	1.00	28.500	5.875	8.500
PMG2000	2000	200	4	35.75	35.00	1.00	29.000	5.875	8.500
PMG2250	2250	225	6	37.75	38.75	1.00	30.750	6.250	9.000
PMG2500	2500	250	6	39.25	40.25	1.00	32.250	6.625	9.500
PMG2750	2750	275	6	41.25	41.75	1.00	33.750	6.875	9.625
PMG3000	3000	300	6	43.00	43.25	1.00	35.250	7.250	10.125
PMG3500	3500	350	6	46.25	46.25	1.00	38.250	7.750	10.625
PMG4000	4000	400	6	49.00	48.75	1.00	40.750	8.250	11.250
PMG5000	5000	500	6	54.25	53.25	1.25	45.250	9.250	12.500

Bridge the World with Leading Infrastructure Solutions

**Versiflex™ HLMR Pot Bearing Assemblies
Uni-Directional PMG Series - 10%**

Structural Bearing Assemblies

2 of 2

DESIGN CONSIDERATION

- A. Bearing assembly component dimensions are based on assumed structural conditions and a skew of 0°.
- B. Translational movements (Y) shown in the chart reflect total required structural movement. Bearing components are detailed to accommodate the structural movement plus a ±1" factor of safety.
- C. Sole plates are designed for a welded connection to a steel girder flange. Sole plate dimensions will vary for bolted connections to steel flanges and/or for bearings supporting concrete superstructure elements.
- D. Masonry plate information has been excluded from the bearing details. Masonry plate dimensions are based on the allowable bearing stress of the substructure unit and the anchorage requirements.

A recommended method of determining the masonry plate thickness is to use a 60° load distribution through the plate. The effective loaded area should be used to calculate the bending moment of the plate and the concrete bearing pressure.

