

Structural Bearing Assemblies

Versiflex™ HLMR Pot Bearing Assemblies Fixed PF Series - 30%

Design Basis: AASHTO 17th Edition w/ Interims – Section 14

Rotation: 0.03 Radians

Horizontal Capacity: 30% of Vertical Capacity

Movement: X = 0"

Y = 0"

Steel Strength: Fy = 50 ksi

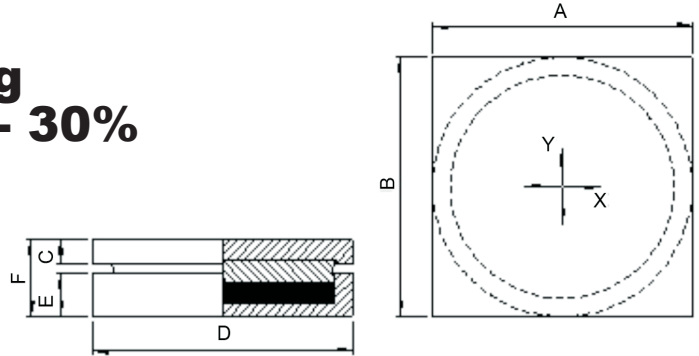

PF SERIES - 30%

Model Number	Vertical Capacity (Klps)	Horizontal Capacity (Klps)	Dimensions (in)					
			A	B	C	D	E	F
PF100	100	30	8.00	8.00	1.00	8.00	2.00	3.825
PF150	150	45	9.75	9.75	1.00	9.75	2.50	4.375
PF200	200	60	11.25	11.25	1.00	11.25	2.75	4.750
PF250	250	75	12.50	12.50	1.00	12.50	3.00	5.000
PF300	300	90	13.50	13.50	1.25	13.50	3.50	5.750
PF350	350	105	14.75	14.75	1.25	14.75	3.75	6.000
PF400	400	120	15.75	15.75	1.25	15.75	3.75	6.125
PF450	450	135	16.75	16.75	1.25	16.75	4.25	6.625
PF500	500	150	17.50	17.50	1.25	17.50	4.25	6.625
PF550	550	165	18.25	18.25	1.25	18.25	4.50	6.875
PF600	600	180	19.25	19.25	1.25	19.25	4.75	7.125
PF650	650	195	20.00	20.00	1.25	20.00	5.00	7.500
PF700	700	210	20.50	20.50	1.25	20.50	5.00	7.500
PF750	750	225	21.50	21.50	1.25	21.50	5.25	7.750
PF800	800	240	22.25	22.25	1.25	22.25	5.25	7.875
PF850	850	255	22.75	22.75	1.25	22.75	5.50	8.125
PF900	900	270	23.50	23.50	1.25	23.50	5.75	8.375
PF950	950	285	24.00	24.00	1.25	24.00	6.00	8.375
PF1000	1000	300	24.75	24.75	1.25	24.75	6.00	8.625
PF1100	1100	330	26.00	26.00	1.50	26.00	6.25	9.250
PF1200	1200	360	27.00	27.00	1.50	27.00	6.50	9.500
PF1300	1300	390	28.00	28.00	1.50	28.00	6.75	9.875
PF1400	1400	420	29.25	29.25	1.50	29.25	7.00	10.000
PF1500	1500	450	30.25	30.25	1.50	30.25	7.25	10.375
PF1600	1600	480	31.25	31.25	1.50	31.25	7.50	10.750
PF1700	1700	510	32.00	32.00	1.50	32.00	7.75	10.875
PF1800	1800	540	33.00	33.00	1.50	33.00	8.00	11.250
PF1900	1900	570	34.00	34.00	1.50	34.00	8.25	11.625
PF2000	2000	600	34.75	34.75	1.50	34.75	8.25	11.750
PF2250	2250	675	37.00	37.00	1.50	37.00	8.75	12.250
PF2500	2500	750	38.75	38.75	1.75	38.75	9.25	13.000
PF2750	2750	825	40.75	40.75	1.75	40.75	9.75	13.500
PF3000	3000	900	42.75	42.75	1.75	42.75	10.00	14.000
PF3500	3500	1050	46.00	46.00	1.75	46.00	11.00	15.000
PF4000	4000	1200	49.00	49.00	1.75	49.00	11.75	15.875
PF5000	5000	1500	54.75	54.75	1.75	54.75	13.00	17.625

Bridge the World with Leading Infrastructure Solutions

**Versiflex™ HLMR Pot Bearing Assemblies
Fixed PF Series - 30%**

Structural Bearing Assemblies

2 of 2

DESIGN CONSIDERATION

- A. Bearing assembly component dimensions are based on assumed structural conditions and a skew of 0°.
- B. Sole plates are designed for a welded connection to a steel girder flange. Sole plate dimensions will vary for bolted connections to steel flanges and/or for bearings supporting concrete superstructure elements.
- C. Masonry plate information has been excluded from the bearing details. Masonry plate dimensions are based on the allowable bearing stress of the substructure unit and the anchorage requirements.

A recommended method of determining the masonry plate thickness is to use a 60° load distribution through the plate. The effective loaded area should be used to calculate the bending moment of the plate and the concrete bearing pressure.

