

### Structural Bearing Assemblies

## Versiflex™ HLMR Pot Bearing Assemblies Multi-Directional PM Series - 10%

**Design Basis:** AASHTO 17th Edition w/ Interims – Section 14

**Rotation:** 0.03 Radians

**Horizontal Capacity:** Internal Components to Resist Friction

**Movement:** X = As Shown Below

Y = As Shown Below

**Steel Strength:** Fy = 50 ksi

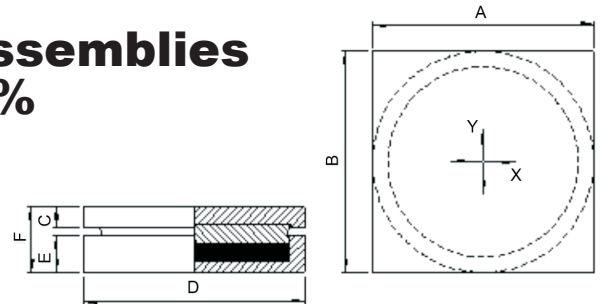

### PM SERIES - 10%

Model Number	Vertical Capacity (Klps)	Horizontal Capacity (Klps)	Dimensions (in)							
			X	Y	A	B	C	D	E	F
PM100	100	10	1	3	9.50	11.50	1.00	8.00	1.75	3.750
PM150	150	15	1	3	10.75	12.75	1.00	9.25	1.75	3.750
PM200	200	20	1	3	12.00	14.00	1.00	10.50	2.00	4.000
PM250	250	25	1	3	13.00	15.00	1.00	11.50	2.00	4.000
PM300	300	30	1	3	13.75	15.75	1.00	12.25	2.25	4.250
PM350	350	35	1	3	14.75	16.75	1.00	13.25	2.25	4.375
PM400	400	40	1	3	15.50	17.50	1.00	14.00	2.25	4.375
PM450	450	45	1	3	16.25	18.25	1.00	14.75	2.50	4.750
PM500	500	50	1	3	16.75	18.75	1.00	15.50	2.50	4.750
PM550	550	55	1	3	17.50	19.50	1.00	16.25	2.75	4.875
PM600	600	60	1	3	18.25	20.25	1.00	17.00	3.00	5.250
PM650	650	65	1	3	18.75	20.75	1.00	17.75	3.00	5.250
PM700	700	70	1	3	19.25	21.25	1.00	18.25	3.00	5.250
PM750	750	75	1	3	20.00	22.00	1.00	19.00	3.25	5.500
PM800	800	80	1	3	20.50	22.50	1.00	19.50	3.25	5.500
PM850	850	85	1	3	21.00	23.00	1.00	20.25	3.25	5.500
PM900	900	90	1	3	21.50	23.50	1.00	20.75	3.50	5.750
PM950	950	95	1	3	22.00	24.00	1.00	21.25	3.50	5.750
PM1000	1000	100	1	3	22.50	24.50	1.00	21.75	3.50	5.750
PM1100	1100	110	1	4	23.50	26.50	1.00	23.00	3.75	6.125
PM1200	1200	120	1	4	24.25	27.25	1.00	23.75	3.75	6.125
PM1300	1300	130	1	4	25.00	28.00	1.00	24.50	4.00	6.375
PM1400	1400	140	1	4	26.00	29.00	1.00	25.75	4.25	6.625
PM1500	1500	150	1	4	26.75	29.75	1.00	26.50	4.25	6.625
PM1600	1600	160	1	4	27.50	30.50	1.00	27.25	4.50	7.000
PM1700	1700	170	1	4	28.25	31.25	1.00	28.25	4.50	7.000
PM1800	1800	180	1	4	29.00	32.00	1.00	29.00	4.75	7.250
PM1900	1900	190	1	4	29.75	32.75	1.00	29.75	4.75	7.250
PM2000	2000	200	1	4	30.50	33.25	1.00	30.50	4.75	7.250
PM2250	2250	225	1	6	32.25	37.00	1.00	32.25	5.25	7.875
PM2500	2500	250	1	6	34.00	38.50	1.00	34.00	5.50	8.250
PM2750	2750	275	1	6	35.75	40.00	1.00	35.75	5.75	8.375
PM3000	3000	300	1	6	37.50	41.50	1.00	37.50	6.00	8.750
PM3500	3500	350	1	6	40.25	44.00	1.00	40.25	6.25	9.000
PM4000	4000	400	1	6	43.00	46.50	1.00	43.00	6.75	9.625
PM5000	5000	500	1	6	48.00	51.00	1.00	48.00	7.50	10.500

Bridge the World with Leading Infrastructure Solutions

**Versiflex™ HLMR Pot Bearing Assemblies**  
**Multi-Directional PM Series - 10%**

## Structural Bearing Assemblies

2 of 2

**DESIGN CONSIDERATION**

- A. Bearing assembly component dimensions are based on assumed structural conditions and a skew of 0°.
- B. Translational movements (X and Y) shown in the chart reflect total required structural movement. Bearing components are detailed to accommodate the structural movement plus a  $\pm 1$ " factor of safety.
- C. Sole plates are designed for a welded connection to a steel girder flange. Sole plate dimensions will vary for bolted connections to steel flanges and/or for bearings supporting concrete superstructure elements.
- D. Masonry plate information has been excluded from the bearing details. Masonry plate dimensions are based on the allowable bearing stress of the substructure unit and the anchorage requirements.

A recommended method of determining the masonry plate thickness is to use a 60° load distribution through the plate. The effective loaded area should be used to calculate the bending moment of the plate and the concrete bearing pressure.

